

No. 9195

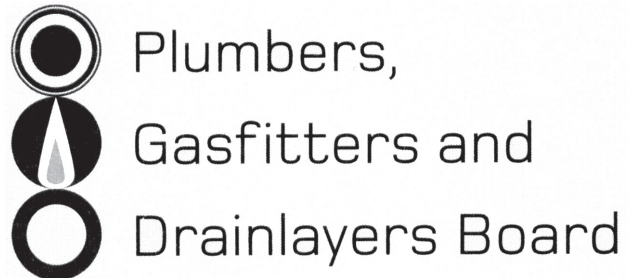

CRAFTSMAN EXAMINATION, JUNE 2009
PLUMBING

ANSWER SCHEDULE

ANSWER 1

- (a) The functions of the Board shall be:
- To make arrangements for the examination of persons practising or intending to practise the plumbing or gasfitting or drainlaying trades:
 - To present or issue, either independently or in conjunction with any other examining body, diplomas or certificates to any such person in recognition of his proficiency in any of those trades:
 - To make recommendations to any person or body concerned with the education or training of any person wishing to enter the plumbing or gasfitting or drainlaying trades, or with regard to any other matter affecting such trades:
 - To ensure that craftsmen gasfitters, gas inspectors, and registered gasfitters maintain an adequate level of competence in the field of work in respect of which they are registered.
 - To exercise disciplinary powers in accordance with the provisions of Part IV of this Act.
 - To institute prosecutions against registered persons or other persons for the breach of any Act or regulation relating to sanitary plumbing, gasfitting, or drainlaying:
 - To make recommendations to the Minister with respect to the making of regulations under this Act, or the making of regulations controlling sanitary plumbing or drainlaying under the Health Act 1956.
 - To record gas certification certificates.
 - To monitor CPD.
- (Any 5, 1 mark each)
- (b) A person who is dissatisfied with a decision or order of the Board may, within 28 days after notice of the decision or order has been communicated to him by the Registrar of the Board, appeal to the High Court against the whole or any part of the decision or order.
- (2 marks)
- (c)
- The building does not have a supply of potable water adequate for its intended use.
 - The building does not have sanitary facilities that are adequate for its intended use.
- (2 marks)
- (d) From the date of issue of the code compliance certificate
- (1 mark)

Total 10 marks

ANSWER 2

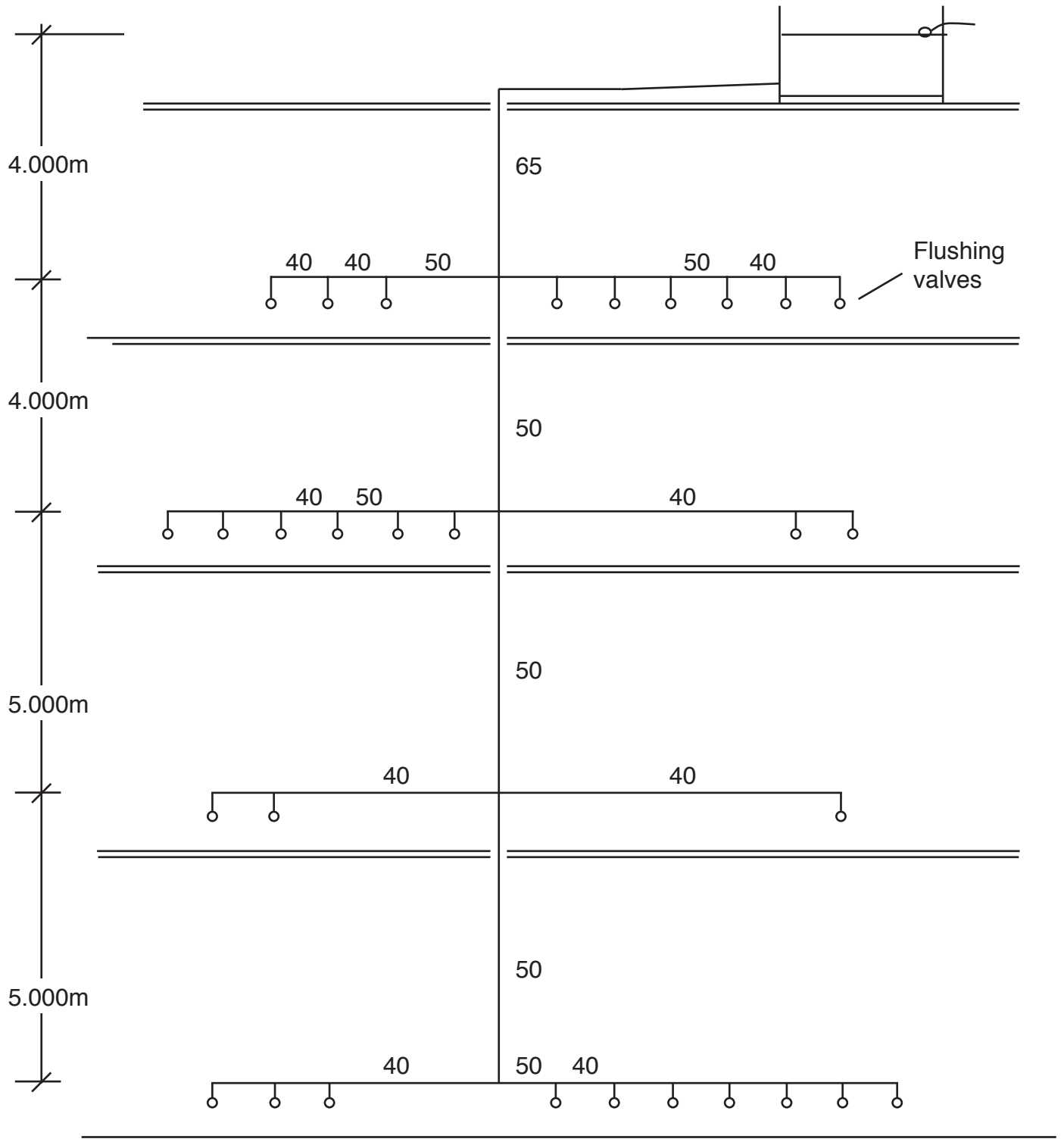

(Start with 8 marks. Deduct 1 mark for each sizing error on the main vertical pipe (from tank) and deduct ½ mark for each sizing error on horizontal laterals)

(b) $30 \times 45 = 1350$ litres

(1 mark)

Total 9 marks

ANSWER 3

$$N = \sqrt{(40 \div 18)^5}$$

$$= \sqrt{2.222^5} \quad (1 \text{ mark})$$

$$= \sqrt{54.165} \quad (1 \text{ mark})$$

$$= 7.359$$

Therefore 7 motel units can be supplied by the ring main. (1 mark)

Total 3 marks

ANSWER 4

(a)

LOADING UNITS			
Fitting or fixture	Loading units	Number of fixtures	Extension
WC cistern	2	3	6
Bath	8	1	8
Basin	1	4	4
Shower	2	2	4
Sink	3	1	3
Laundry tub	3	1	3
Washing machine/dishwasher	3	2	6
Mains pressure water heater	8	1	8
Hose tap	4	3	12
TOTAL LOADING UNITS			54

(½ mark each correct line), (5 marks)

(b) PSFR = 0.64 l/s

$$= 0.64 \times 60$$

$$= 38.4 \text{ l/M} \quad (2 \text{ marks})$$

(c) 24 + 7 = 31m

Therefore the pump is model HJ400 (2 marks)

Total 9 marks

ANSWER 5

FITTING, FIXTURE OR INSTALLATION	HIGH	MEDIUM	LOW
Carbonated drink dispenser		✓	
Hair dressers' sinks and beauty salons	✓		
Swimming pools and spas		✓	
Auxiliary water supplies		✓	
Dental equipment	✓		
Livestock water supplies with added chemicals	✓		
Boiler, chiller and cooling tower make-up water	✓		
Pest control equipment	✓		
Car and factory washing facilities	✓		
Non-carbonated drink dispenser			✓
Fire sprinkler systems using toxic additives	✓		
Untreated water storage tanks		✓	

(½ mark each correct cell)

Total 6 Marks**ANSWER 6**

- (a) (i) 115kPa
(ii) 85kPa
(iii) 73kPa

NB: Tolerance + - 5kPa

(1 mark each), (3 marks)

- (b) DN 40mm.

(1 mark)

Total 4 Marks

ANSWER 7

- (a) – To ensure that the first check valve is watertight and maintains a minimum differential pressure of 35kPa.
- To ensure that the second check valve is watertight against back-pressure.
- To ensure that the relief valve opens at not less than 14kPa. (3 marks, 1 mark each)
- (b) A back siphonage prevention device.
- Air gap (½ mark) + High hazard backflow device (½ mark) (1 mark)

Total 9 Marks

ANSWER 8

Daily energy use = $(4.5 \times 4.8) + (6.25 \times 9.6)$
= $21.6 + 60$
= 81.6 kWh (1 mark)

Cost per kWh = $21.47 + 0.16$
= 21.63c (1 mark)

Daily energy cost = 21.63×81.6
= 1765.008
= $1765.008 \div 100$
= \$17.65 (1 mark)

Annual energy cost = 17.65×304
= \$5365.60 (1 mark)

Annual line charge = 65.8×365
= $24017 \div 100$
= \$240.17 (1 mark)

Total annual charges = $5365.60 + 240.17$
= \$5605.77 (1 mark)

Deduct GST = $5605.77 \div 9 \times 8$
= \$4982.91 (1 mark)

Total 7 Marks

- NB: If 304 days are used to calculate annual line charge: \$200.03 (½ mark)
Total annual charges = \$5565.63
Deduct GST = \$4947.22 (½ mark) (Total 6 marks)

ANSWER 9

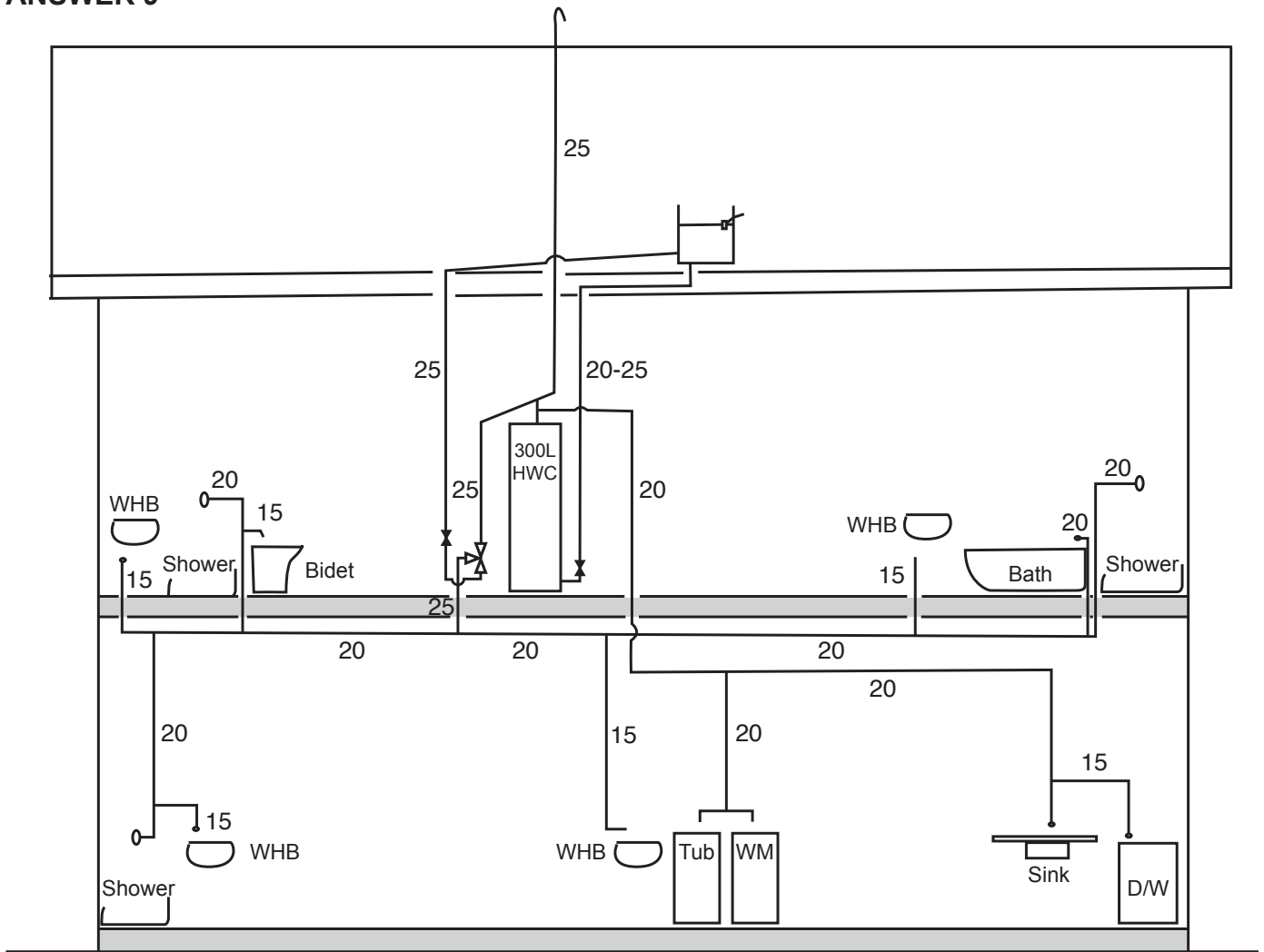

(Start with 10 marks. Deduct 1 mark for incorrect tempering valve diameter and 1 mark for each incorrect or missing pipe diameter to and from the tempering valve. Deduct ½ mark for each other incorrect or missing pipe diameter)

Total 4 Marks

ANSWER 10

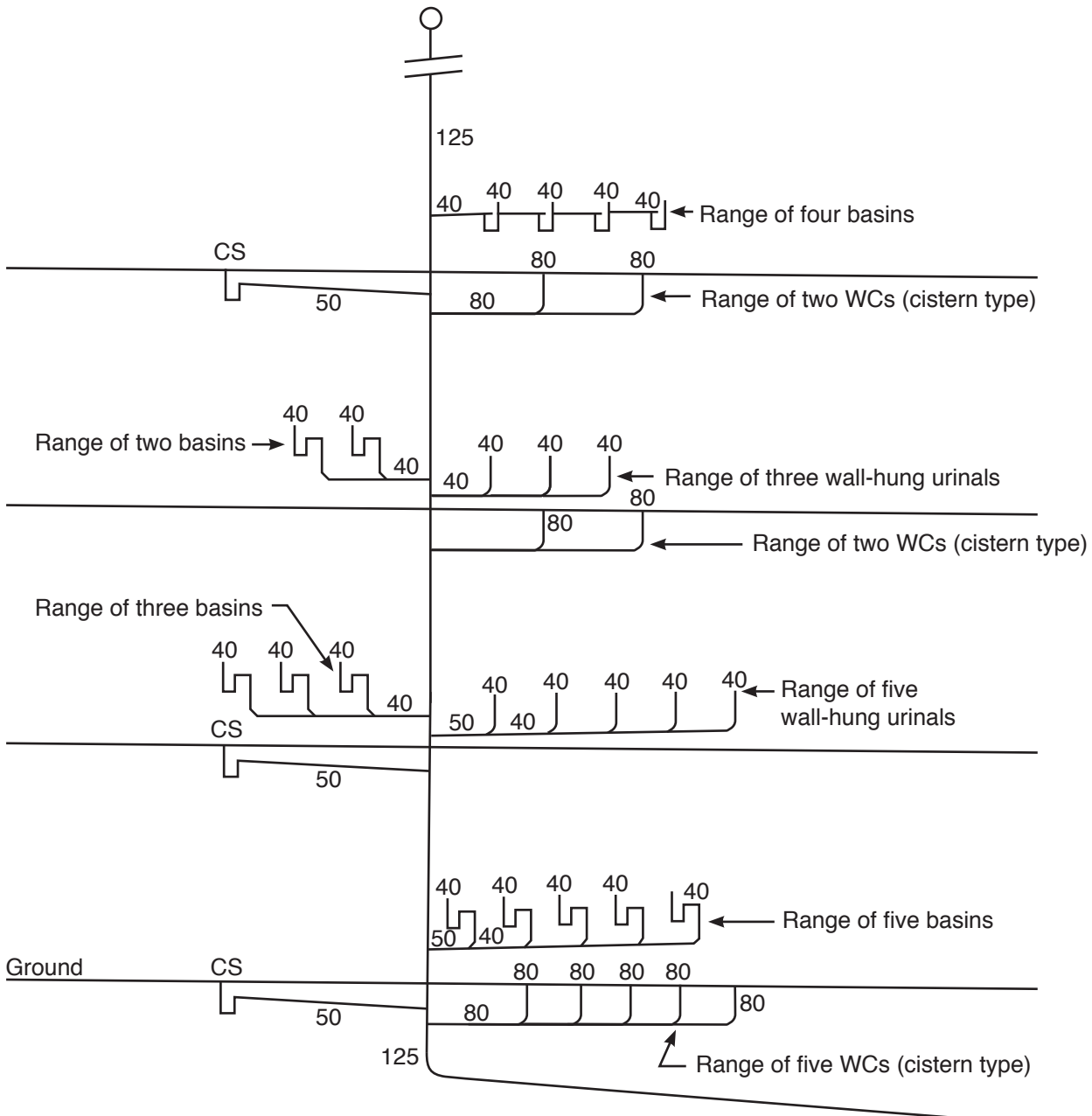

(Start with 10 marks and take ½ mark off for each pipe size missing or incorrect on discharge pipes and branch discharge pipes. Deduct 1 mark for each incorrect stack size or stack vent size)

Total 10 Marks

ANSWER 11

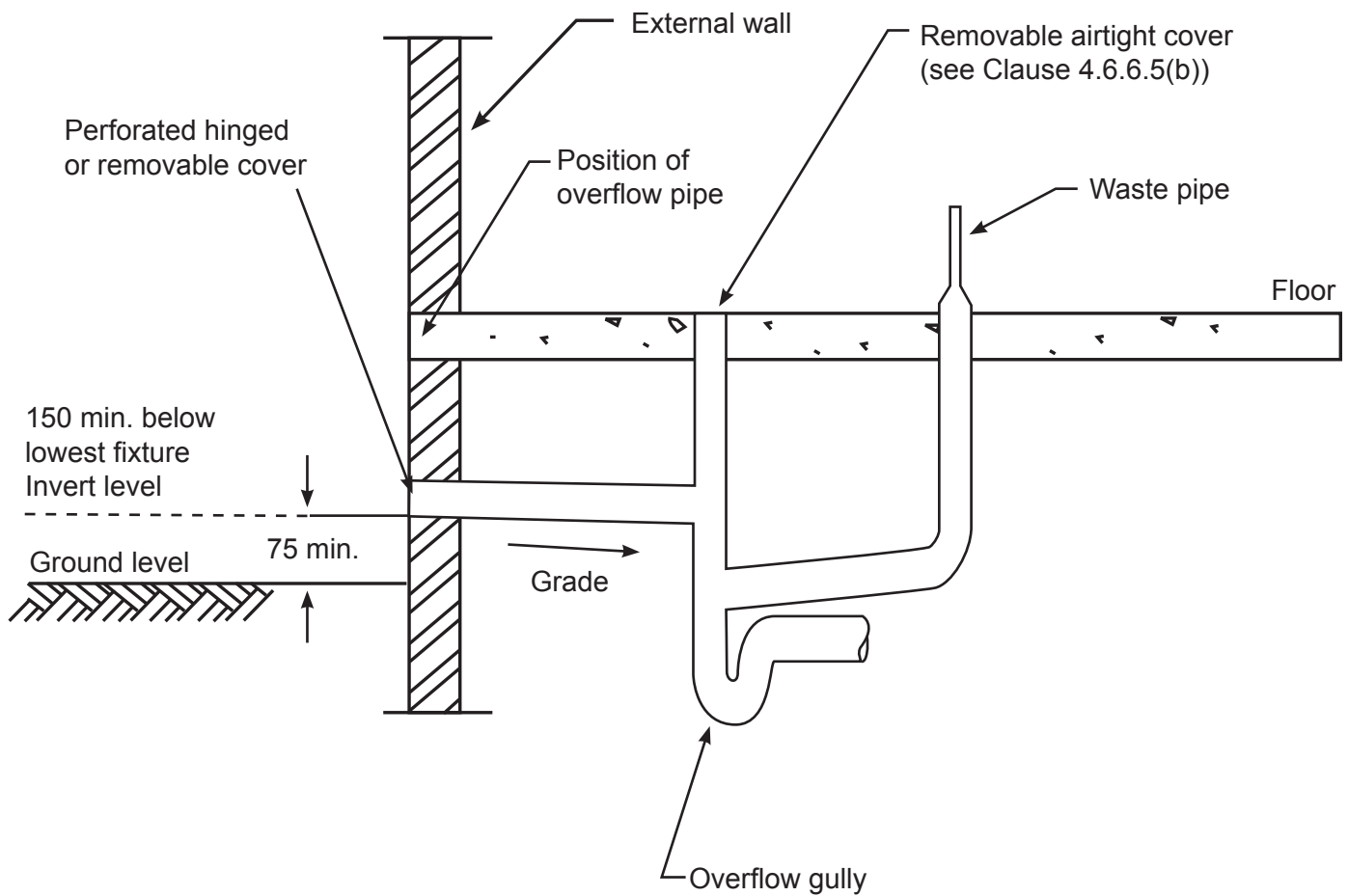

- ½ mark for the perforated hinged or removable cover
 - ½ mark for the removable airtight cover
 - ½ mark for the 150mm (minimum) below lowest fixture
 - ½ mark for the 75mm (minimum) between invert level and ground level
 - 1 mark for the waste pipe
 - 1 mark for showing the overflow from the gully (gully overflow)
 - 1 mark for the grade
- Acceptable solutions exist and to be researched on appearance.
(5 marks)

Total 5 marks

ANSWER 12

- (1) The water seal of the trap may be maintained by a charge pipe from a flushing device, connecting at the heel or the base of the flush pipe with a union.
- (2) A charge pipe from a tap set or a drain from a hot water relief valve, which shall drain over a tundish so that a minimum of a 25 mm air gap is maintained
- (3) A tap or extended laundry tub arm located in close proximity to the floor waste gully and which can discharge on to the floor within the same room or compartment as the floor waste gully.
- (4) Automatic trap primer device.

(1 mark each)

Total 4 marks

ANSWER 13

- (a) $36\text{m} \times 9\text{m} = 324\text{m}^2$
 $8\text{m} \times 5\text{m} = 40\text{m}^2$
 $8\text{m} \times 6\text{m} = 48\text{m}^2$
 412m^2 (2 marks)

- (b) $\frac{412}{70} = 5.885$

Therefore 6 x 74mm downpipes will be needed (2 marks)

- (c) 8000mm^2 to 9000mm^2 (1 mark)

Total 5 marks

ANSWER 14

- (a) – The relief valve must be compatible with the system it is to serve.
– It must have a discharge rate (capacity) greater than the cold water supply rate.
– It must have a pressure rating less than the maximum working pressure of the storage vessel being served.
– It must be rated to the energy input of the heat source.
(Any 3, 1 mark each), (3 marks)

- (b) The cold water expansion valve must have a pressure rating in excess of the pressure reducing or pressure limiting valve but less than the pressure rating of the relief valve.
(1 mark)

- (c) – It must be accessible for servicing.
– It must comply with minimum head requirements (subject to the maximum available head).
– It must be within 2m of the hot water cylinder outlet.
(Any 2, 1 mark each), (2 marks)

Total 6 marks

ANSWER 15

- (a) – When the developed length of the waste pipe from the crown of the water trap to the gully trap is greater than 3.5 metres.
- When the waste pipe discharges to a combined waste pipe.
- Where any 32mm discharge pipe to a gully trap has a vertical drop of greater than 1.5 m
- All fixtures connected to a stack, except the highest connection (for lengths refer to table
- (4 marks)
- (b) Additional venting is provided for in discharge stacks serving sanitary fixtures on each floor of a three-storey building, by means of a relief vent connected at the base of the stack and interconnected with other vents within the system.
- (1 mark)
- (c) – To relieve a pressure ahead of flow in the waste pipes discharging to the sealed gully.
- To admit fresh air to the waste pipes thus duplicating the effect of the open grating in a standard gully trap.
- (2 marks)
- (d) A sealed gully ventilating pipe must be independent of any other system ventilating pipe in order to avoid the possibility of cross flow of foul gases into the waste pipes discharging to the sealed gully.
- (1 mark)

Total 8 marks

